

I.N.G. FIXATIONS

Fixations lourdes dans le béton non fissuré



AGRÉMENT TECHNIQUE EUROPÉEN



ATE - 14/0339

Béton non fissuré

CHEVILLE CONE INTERIEUR

**Cheville à expansion par frappe pour
ancrage dans le béton non fissuré**

ASSOCIATION



**SOCOTEC
QUALITÉ**

Membre Adhérent n° 586



ZAVOD ZA
GRADBENIŠTVO
SLOVENIJE

SLOVENIAN
NATIONAL BUILDING
AND CIVIL ENGINEERING
INSTITUTE



član EOTA
Member of EOTA

Dimičeva 12
1000 Ljubljana, Slovenija

Tel.: +386 (0)1-280 44 72, 280 45 37

Fax: +386 (0)1-280 44 84

E-pošta: info.ta@zag.si

http://www.zag.si/ts

European Technical Assessment

ETA-14/0339
of 18.09.2014

English version prepared by ZAG Ljubljana

I GENERAL PART

Komercialno ime
Trade name

CHEVILLE DOUILLE METALLIQUE

Imetnik tehnične ocene
Holder of Technical Assessment

I.N.G. Fixations
ZI de Chassende
43005 LE PUY-EN-VELAY
France

Družina proizvoda

Deformacijsko kontrolirano ekspanzijsko
galvansko pocinkano kovinsko sidro velikosti M6,
M8, M10, M12, M16 in M20 za vgradnjo v
nerazpokani beton

Product family

Deformation - controlled expansion anchor made of
galvanized steel of sizes M6, M8, M10, M12, M16
and M20 for use in non-cracked concrete

Proizvodni obrat
Manufacturing plant

USINE 2

Ta Evropska tehnična ocena vsebuje
This European Technical Assessment
contains

10 strani vključno s 7 prilogami, ki so sestavni del te
ocene
10 pages including 7 annexes, which form an integral part of the
document

Ta Evropska tehnična ocena je
izdana na podlagi Uredbe (EU) št.
305/2011 na podlagi

Smernice za evropska tehnična soglasja ETAG 001 –
del 1 in 4, izdaja 2013, ki se uporablja kot EAD

This European Technical Assessment is
issued in according to Regulation (EU)
No 305/2011, on the basis of

Guideline for European Technical Approval ETA 001 – part 1 and
4, edition 2013, used as EAD

Translations of this European Technical Assessment in other languages shall fully correspond to the original issued document and should be identified as such.

Communication of this European Technical Assessment, including transmission by electronic means, shall be in full (excepted the confidential Annex(es) referred to above). However, partial reproduction may be made, with the written consent of the issuing Technical Assessment Body. Any partial reproduction has to be identified as such.

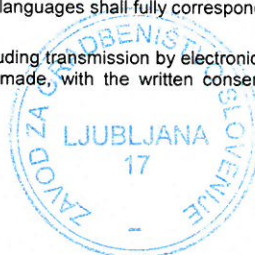

II SPECIFIC PART OF THE EUROPEAN TECHNICAL ASSESSMENT

1 Technical description of the product

The CHEVILLE DOUILLE METALLIQUE in the range of M6, M8, M8×40, M10, M12, M16 and M20 is an anchor made of galvanised steel, which is placed into a drilled hole and anchored by deformation - controlled expansion.

An illustration and description of the anchor are given in Annexes A1 and A2.

2 Specification of the intended use

The performances given in Chapter 3 are only valid if the anchor is used in compliance with the specifications and conditions given in Annexes B1 to B4.

The provisions made in this European Technical Assessment are based on an assumed working life of the anchor of 50 years. The indications given on the working life cannot be interpreted as a guarantee given by the manufacturer, but are to be regarded only as a means for choosing the right products in relation to the expected economically reasonable working life of the works.

3 Performance of the product and references to the methods used for this assessment

3.1 Mechanical resistance and stability (BWR 1)

The essential characteristics for mechanical resistance and stability are listed in Annex C1.

3.2 Safety in case of fire (BWR 2)

For safety in fire no performance was determined for this product.

3.3 Hygiene, health and environment (BWR 3)

Regarding dangerous substances contained in this European Technical Assessment, there may be requirements applicable to the products falling within its scope (e.g. transported European legislation and national laws, regulations and administrative provisions). In order to meet provisions of the regulation (EU) No 305/2011, these requirements need also to be complied with, when they apply.

3.4 Safety in use (BWR 4)

For basic requirement safety in use the same criteria are valid as for basic requirement mechanical resistance and stability.

3.5 Protection against noise (BWR 5)

Not relevant.

3.6 Energy economy and heat retention (BWR 6)

Not relevant.

3.7 Sustainable use of natural resources (BWR 7)

For sustainable use of natural resources no performance was determined for this product.

3.8 General aspects relating to fitness for use

Durability and serviceability are only ensured if specifications of intended use according to Annex B1 are kept.

4 Assessment and verification of constancy of performance (AVCP)

According to the decision 96/582/EC of the European Commission¹ the system of assessment and verification of constancy of performance (see Annex V to Regulation (EU) No 305/2011) given in the following table apply.

¹



Product	Intended use	Level of class	System
Metal anchors for use in concrete	For fixing and/or supporting to concrete, structural elements (which contributes to the stability of the works) or heavy units	-	1

5 Technical details necessary for the implementation of the AVCP system

5.1 Tasks for the manufacturer

The manufacturer shall exercise permanent internal control of production of concerned product. All the elements, requirements and provisions adopted by the manufacturer shall be documented in a systematic manner in the form of written policies and procedures, including records of results performed. This production control system shall ensure that the product is in conformity with this European Technical Assessment.

The manufacturer may only use raw materials stated in the technical documentation of this European Technical Assessment.

The factory production control shall be in accordance with the Control plan which is a part of the technical documentation of this European Technical Assessment. The Control plan² is laid down in the context of the factory production control system operated by the manufacturer and deposited at Slovenian National Building and Civil Engineering Institute (ZAG Ljubljana). The results of factory production control shall be recorded and evaluated in accordance with the provisions of the Control plan.

The manufacturer shall, on the basis of a contract, involve a body, which is notified for the tasks referred to in a section 4 in the field of anchors in order to undertake the actions laid down in section 5.2. For this purpose the Control plan referred to in sections 5.1 and 5.2 shall be handed over by the manufacturer to the notified body involved.

The manufacturer shall make a Declaration of performance, stating that the construction product is in conformity with the provisions of this European Technical Assessment.

5.2 Tasks for the notified bodies

The notified body shall retain the essential points of its actions defined in Annex V of Regulation (EU) No. 305/2011 for system 1 and state results obtained and conclusions drawn in a written report.

The notified certification body involved by the manufacturer shall issue an EC certificate of constancy of performance the product stating the conformity with the provisions of this European Technical Assessment.

In cases where the provisions of the European Technical Assessment and its control plan are no longer fulfilled the notified body shall withdraw the certificate of constancy of performance and inform the Slovenian National Building and Civil Engineering Institute (ZAG Ljubljana) without delay.

Issued in Ljubljana on 18.09.2014

Signed by:

Franc Capuder, M.Sc., Research Engineer

Head of Service of TAB



²

The Control plan is a confidential part of the technical documentation of this European Technical Assessment, but not published together with the ETA, and handed over only to the approved body or bodies involved in the procedure of attestation of conformity.

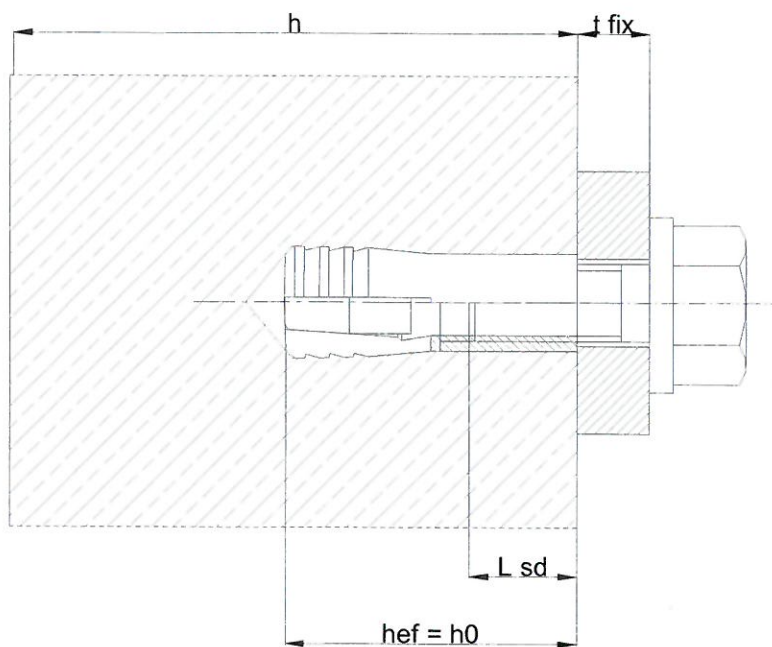
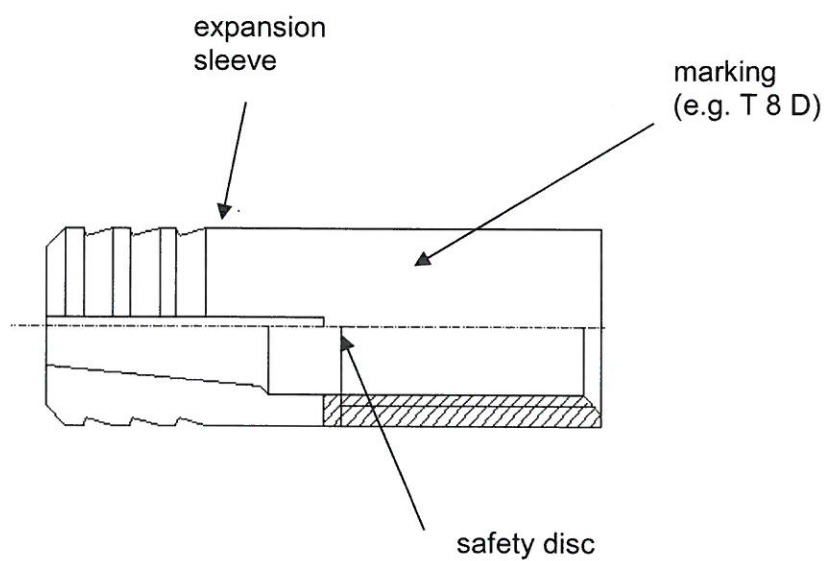

<p>CHEVILLE DOUILLE METALIQUE</p>	<p>Annex A1</p>
<p>Product description Product and intended use</p>	



Table A1: Materials

Part	Component	Material		f_{uk} [N/mm ²]
1	Expansion sleeve	Machined steel acc. to EN 10277-3 Galvanised acc. to EN ISO 4042 thickness of galvanisation $\geq 5\mu\text{m}$.		570
2	Cone	M6, M8, M10, M12, M16	Cold formed steel acc. to EN 10278/EN 10016 or cold formed steel acc. to EN 10278/EN 10263-2 Galvanised acc. to EN ISO 4042 thickness of galvanisation $\geq 5\mu\text{m}$.	
		M20	Machined steel acc. to EN 10277-3 Galvanised acc. to EN ISO 4042 thickness of galvanisation $\geq 5\mu\text{m}$.	

CHEVILLE DOUILLE METALIQUE

Product description
Materials

Annex A2



Specifications of intended use

Anchorage subjected to:

- Static and quasi static load.

Base materials:

- Non-cracked concrete.
- Reinforced and unreinforced normal weight concrete of strength class C20/25 at minimum and C50/60 at maximum according to EN 206-1:2000/A2:2005.

Use conditions (Environmental conditions):

- Structures subjected to dry internal conditions.

Design:

- Anchorages are designed under the responsibility of an engineer experienced in anchorages and concrete work.
- Verifiable calculation notes and drawings are prepared taking into account of the load to be anchored. The position of the anchor is indicated on the design drawings (e.g. position of the anchor relative to reinforcement or to supports, etc.)
- Anchorages under static and quasi-static actions are designed in accordance with ETAG 001, Annex C, design method A, Edition August 2010.

Installation:

- Anchor installation carried out by appropriately qualified personnel and under supervision of the person responsible for technical matters of the site.
- Use of the anchor only supplied by the manufacturer without exchanging the components of an anchor.
- Anchor installation in accordance with the manufacturer's specification and drawings and using the appropriate tools.
- Checks before placing the anchor to ensure that the strength class of the concrete in which the anchor is to be placed is in the range given and is not lower than that of the concrete to which the characteristic loads apply for.
- Check of concrete being well compacted, e.g. without significant voids.
- Effective anchorage depth, edge distances and spacing not less than the specified values without minus tolerances.
- Hole drilling by hammer drill.
- Cleaning of the hole of drilling dust.
- Positioning of the drill holes without damaging the reinforcement.
- In case of aborted hole, drilling of new hole at a minimum distance of twice the depth of the aborted hole, or smaller distance provided the aborted drill hole is filled with high strength mortar and no shear or oblique tension loads in the direction of aborted hole.
- Anchor expansion by impact on the cone using the manual setting tool given in Annex B3. The anchor is properly set if the stop of the setting tool reaches the expansion sleeve. The setting tool leaves visible mark on the sleeve.
- The fastening screw or threaded rod shall correspond to the requirements given in Annex B4.
- Application of the torque moment given in Annex B4 using a calibrated torque wrench.

CHEVILLE DOUILLE METALIQUE

Intended use
Specification

Annex B1



Expansion sleeve

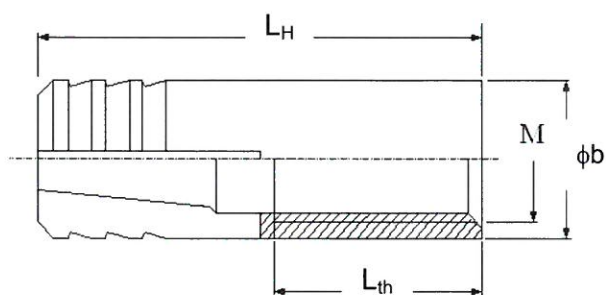

Cone

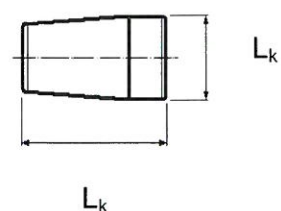

Table B1: Dimensions

Anchor size	Expansion sleeve				Cone	
	Thread	ϕb	L_H	L_{th}	ϕk	L_k
M6	M6	8	30	17	5	10
M8	M8	10	30	14	6,5	12
M8 X 40	M8		40	20		
M10	M10	12	40	15	8,2	16
M12	M12	15	50	20	10,3	20
M16	M16	20	65	25	13,8	27
M20	M20	25	80	35	17,5	30

CHEVILLE DOUILLE METALIQUE

Intended use
Dimensions of an anchor

Annex B2



Setting tool

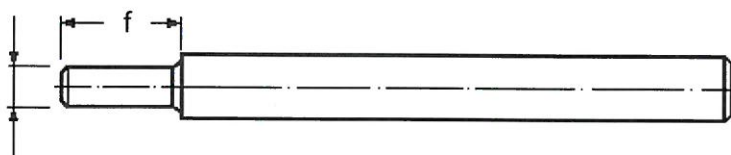

Table B2: Dimensions of setting tool

Anchor	ϕm	f
M6	5	20
M8	6,5	18
M8x40		28
M10	8	24
M12	10	30
M16	13,5	38
M20	17,5	50

CHEVILLE DOUILLE METALIQUE

Intended use
Setting tool

Annex B3

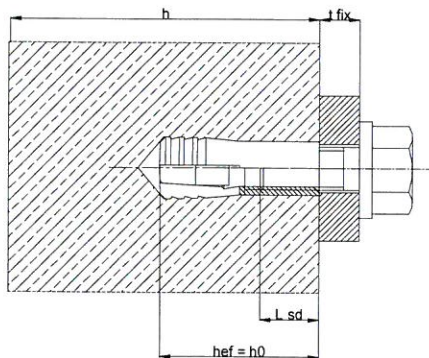

Table B3: Installation parameters for M6, M8 and M8×40

		M6	M8	M8×40
Nominal diameter of drill bit	d_0 [mm]	8	10	10
Cutting diameter of drill bit	$d_{cut} \leq$ [mm]	8,45	10,45	10,45
Diameter of clearance hole in the fixture	d_f [mm]	7	9	9
Depth of drill hole	h_0 [mm]	30	30	40
Minimum thickness of the member	h_{min} [mm]	100	100	100
Minimum spacing	s_{min} [mm]	60	80	80
Minimum edge distance	c_{min} [mm]	95	110	110
Effective anchorage depth	h_{ef} [mm]	30	30	40
Torque moment	T_{inst} [Nm]	4	8	8
Actual length of the thread	L_{th} [mm]	15	14	20
Minimal screwing depth	$L_{sd,min}$ [mm]	7	9	9

Table B4: Installation parameters for M10, M12, M16 and M20

		M10	M12	M16	M20
Nominal diameter of drill bit	d_0 [mm]	12	15	20	25
Cutting diameter of drill bit	$d_{cut} \leq$ [mm]	12,5	15,5	20,55	25,55
Diameter of clearance hole in the fixture	d_f [mm]	12	14	18	22
Depth of drill hole	h_0 [mm]	40	50	65	80
Minimum thickness of the member	h_{min} [mm]	120	150	160	250
Minimum spacing	s_{min} [mm]	100	120	150	160
Minimum edge distance	c_{min} [mm]	135	165	200	260
Effective anchorage depth	h_{ef} [mm]	40	50	65	80
Torque moment	T_{inst} [Nm]	15	35	60	120
Actual length of the thread	L_{th} [mm]	15	20	25	35
Minimal screwing depth	$L_{sd,min}$ [mm]	11	13	18	22



Requirements for the fastening screw or threaded rod:

- minimum property class is 8.8 according to EN ISO 898,
- minimum screwing depth is $L_{sd,min}$,
- the length of fastening screw shall be determined depending on thickness of fixture t_{fix} , admissible tolerances and available screw length L_{th} as well as minimum screwing depth $L_{sd,min}$.

CHEVILLE DOUILLE METALIQUE

Intended use
Installation properties

Annex B4



Table C1: Essential characteristic

Essential characteristic			Performance						
			M6×30 ¹⁾	M8 ¹⁾	M8×40	M10	M12	M16	M20
Podatki za vgradnjo									
d₀	Nominal diameter of drill bit	[mm]	8	10	10	12	15	20	25
h₀	Anchorage depth	[mm]	30	30	40	40	50	65	80
h_{ef}	Effective anchorage depth	[mm]	30	30	40	40	50	65	80
h_{min}	Minimum thickness of concrete member	[mm]	100	100	160	120	150	160	250
T_{inst}	Torque moment	[Nm]	4	8	8	15	35	60	120
s_{min}	Minimum spacing	[mm]	60	80	80	100	120	150	160
c_{min}	Minimum edge distance	[mm]	95	110	110	135	165	200	260
Tension steel failure resistance									
N_{Rk,s}	Characteristic tension steel failure	[kN]	10	14	14	17	33	60	95
γ_{MsN}	Partial safety factor	[-]	1,55						
Pull-out failure mode									
N_{Rk,p}	Characteristic pull-out failure in non-cracked concrete	[kN]	5	7,5	7,5	7,5	16	20	30
γ₂	Partial safety factor	[-]	1,2	1,4	1,4	1,4	1,4	1,4	1,0
γ_{Mp}		[-]	1,8	2,1	2,1	2,1	2,1	2,1	1,5
s_{cr,N}	Characteristic spacing	[mm]	3 × h _{ef}						
c_{cr,N}	Characteristic edge distance	[mm]	1,5 × h _{ef}						
ψ_C C30/37	Increasing factor for N _{Rk,p} in non-cracked concrete	[-]	1,00	1,07				1,22	
ψ_C C40/50		[-]		1,14				1,41	
ψ_C C50/60		[-]		1,20				1,55	
Splitting failure mode									
s_{cr,sp}	Characteristic spacing	[mm]	160	190	190	270	330	400	520
c_{cr,sp}	Characteristic edge distance	[mm]	80	95	95	135	165	200	260
Displacement under tension load									
Concrete C20/25									
N	Service tension load	[kN]	2,0	2,9	2,6	2,6	5,4	9,5	14,3
δ_{N0}	Short term displacement	[mm]	0,094	0,004	0,072	0,094	0,040	0,020	0,075
δ_{N∞}	Long term displacement	[mm]	0,094	0,014	0,072	0,094	0,040	0,020	0,075
Concrete C50/60									
N	Service tension load	[kN]	2,0	3,6	3,1	3,1	6,5	14,8	22,1
δ_{N0}	Short term displacement	[mm]	0,027	0,037	0,036	0,244	0,364	0,128	0,060
δ_{N∞}	Long term	[mm]	0,027	0,037	0,036	0,244	0,364	0,128	0,060
Shear steel failure									
V_{Rk,s}	Characteristic shear steel failure	[kN]	4,4	6,9	6,9	8,7	16,4	30,0	47,5
M⁰_{Rk,s}	Bending moment characteristic failure	[Nm]	16	28	28	44	100	245	487
γ_{MsV}	Partial safety factor	[-]	1,30						
Shear concrete edge failure									
l_{ef}	Effective anchorage depth	[mm]	25	30	30	40	50	65	80
Displacement under shear load									
V	Service shear load	[kN]	2,4	3,8	3,8	4,8	9,0	16,5	26,1
δ_{V0}	Short term displacement	[mm]	1,017	0,800	0,800	0,637	1,527	1,138	1,429
δ_{V∞}	Long term displacement	[mm]	1,526	1,200	1,200	0,956	2,290	1,707	2,144

¹⁾ For application with statically indeterminate structural components only

CHEVILLE DOUILLE METALIQUE

Design according to ETAG 001, Annex C
Essential requirements

Annex C1

