

# I.N.G. FIXATIONS

*Fixations lourdes dans le béton*



---

*AGRÉMENT TECHNIQUE EUROPÉEN*



**ETE - 02/0030**

**Option 1 - Béton fissuré et non fissuré**

**CHEVILLE FIXATIONS LOURDES - CS**

**Cheville à expansion par serrage à couple contrôlé en acier électrozingué pour ancrage dans le béton fissuré et non fissuré**

---



I.N.G. Fixations - ZI de Chassende BP 90168 43005 Le Puy en Velay cedex France

Tél: +33 (0)4 71 05 59 03 - Fax: +33 (0)4 71 09 35 46 - [ing.fixations.info@orange.fr](mailto:ing.fixations.info@orange.fr) - [www.ingfixations.fr](http://www.ingfixations.fr)

Approval body for construction products  
and types of construction

Bautechnisches Prüfamt

An institution established by the Federal and  
Laender Governments



## European Technical Assessment

**ETA-02/0030**  
**of 27 February 2018**

English translation prepared by DIBt - Original version in German language

### General Part

Technical Assessment Body issuing the  
European Technical Assessment:

Deutsches Institut für Bautechnik

Trade name of the construction product

Highload Anchor SZ

Product family  
to which the construction product belongs

Mechanical anchor for use  
in concrete

Manufacturer

MKT  
Metall-Kunststoff-Technik GmbH & Co. KG  
Auf dem Immel 2  
67685 Weilerbach

Manufacturing plant

MKT  
Metall-Kunststoff-Technik GmbH & Co. KG  
Auf dem Immel 2  
67685 Weilerbach

This European Technical Assessment  
contains

20 pages including 3 annexes which form an integral part  
of this assessment

This European Technical Assessment is  
issued in accordance with Regulation (EU)  
No 305/2011, on the basis of

EAD 330232-00-0601

This version replaces

ETA-02/0030 issued on 22 August 2017

The European Technical Assessment is issued by the Technical Assessment Body in its official language. Translations of this European Technical Assessment in other languages shall fully correspond to the original issued document and shall be identified as such.

Communication of this European Technical Assessment, including transmission by electronic means, shall be in full. However, partial reproduction may only be made with the written consent of the issuing Technical Assessment Body. Any partial reproduction shall be identified as such.

This European Technical Assessment may be withdrawn by the issuing Technical Assessment Body, in particular pursuant to information by the Commission in accordance with Article 25(3) of Regulation (EU) No 305/2011.

**Specific Part**

**1 Technical description of the product**

The Highload Anchor SZ is an anchor made of galvanised steel or made of stainless steel which is placed into a drilled hole and anchored by torque-controlled expansion. The following anchor types are covered:

- Anchor type SZ-B with threaded bolt,
- Anchor type SZ-S with hexagon head screw,
- Anchor type SZ-SK with countersunk washer and countersunk screw.

The product description is given in Annex A.

**2 Specification of the intended use in accordance with the applicable European Assessment Document**

The performances given in Section 3 are only valid if the anchor is used in compliance with the specifications and conditions given in Annex B.

The verifications and assessment methods on which this European Technical Assessment is based lead to the assumption of a working life of the anchor of at least 50 years. The indications given on the working life cannot be interpreted as a guarantee given by the producer, but are to be regarded only as a means for choosing the right products in relation to the expected economically reasonable working life of the works.

**3 Performance of the product and references to the methods used for its assessment**

**3.1 Mechanical resistance and stability (BWR 1)**

Essential characteristic	Performance
Characteristic resistance for static and quasi-static loading	See Annex C1 to C5
Characteristic resistance for seismic performance category C1 and C2	See Annex C6 to C7
Displacements under tension and shear loads	See Annex C9 and C10

**3.2 Safety in case of fire (BWR 2)**

Essential characteristic	Performance
Reaction to fire	Anchorage satisfy requirements for Class A1
Resistance to fire	See Annex C8

English translation prepared by DIBt

**4 Assessment and verification of constancy of performance (AVCP) system applied, with reference to its legal base**

In accordance with the European Assessment Document EAD 330232-00-0601 the applicable European legal act is: [96/582/EC].

The system to be applied is: 1

**5 Technical details necessary for the implementation of the AVCP system, as provided for in the applicable EAD**

Technical details necessary for the implementation of the AVCP system are laid down in the control plan deposited with Deutsches Institut für Bautechnik.

Issued in Berlin on 27 February 2018 by Deutsches Institut für Bautechnik

Dr.-Ing. Lars Eckfeldt  
p. p. Head of Department

*beglaubigt:*  
Lange

## Highload Anchor SZ

### Anchor type SZ-B with threaded bolt

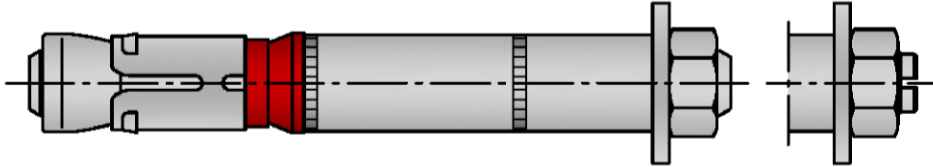

SZ-B (M6-M24)  
SZ-B (M8-M16) A4

### Anchor type SZ-S with hexagon head screw

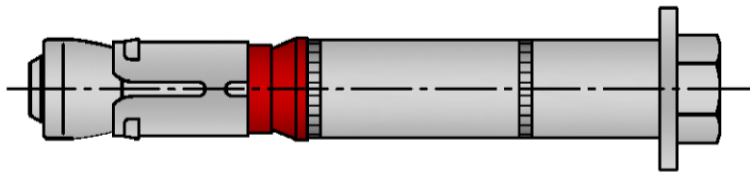

SZ-S (M6-M24)  
SZ-S (M8-M16) A4

### Anchor type SZ-SK with countersunk washer and countersunk screw

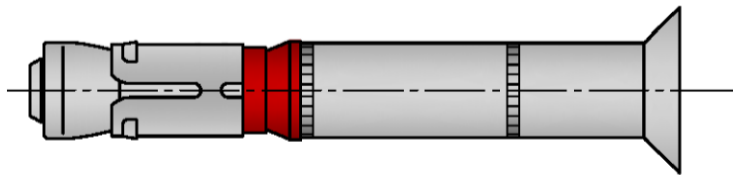

SZ-SK (M6-M12)  
SZ-SK (M8-M12) A4

## Installation condition

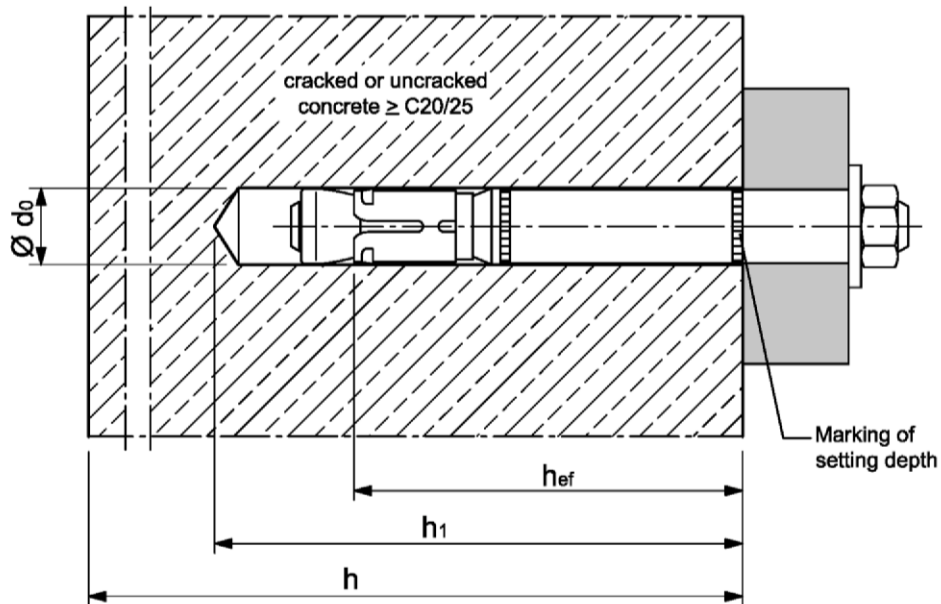

## Highload Anchor SZ

Product description  
Product and installation situation

Annex A1

**SZ-B**

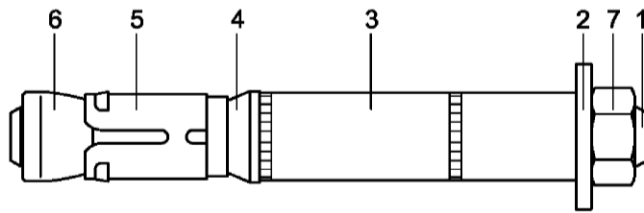

**SZ-S**

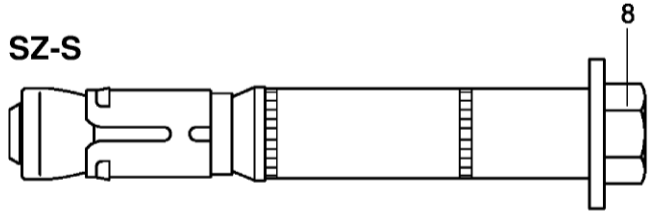

**SZ-SK**

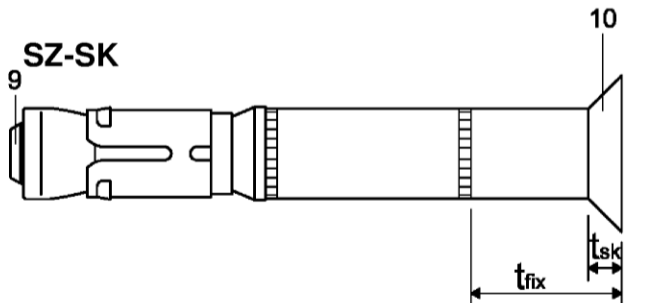

**Marking:**

expansion sleeve:

- Identifying mark of manufacturing plant ◇
- additional marking of stainless steel A4 A4
- Anchor identity (alternatively on distance sleeve) SZ
- size of thread (alternatively M10 on distance sleeve)

Distance sleeve:

- Diameter 15
- max. thickness of fixture 25
- additional marking for countersunk version SK

marking on the washer of anchor size SZ 24/M16L L

**Table A1: Designation of anchor parts and materials**

Part	Designation	Materials galvanised $\geq 5 \mu\text{m}$ , acc. to EN ISO 4042:1999	Stainless steel A4
1	Threaded bolt	Steel, Strength class 8.8, EN ISO 898-1:2013	Stainless steel, 1.4401, 1.4404 or 1.4571, EN 10088:2014
2	Washer	Steel, EN 10139:2016	Stainless steel, EN 10088:2014
3	Distance sleeve	Steel tube EN 10305-2:2016, EN 10305-3:2016;	Steel tube stainless steel, 1.4401, 1.4404 or 1.4571; EN 10217-7:2014, EN 10216-5:2013
4	Ring	Polyethylene	Polyethylene
5	Expansion sleeve	Steel, EN 10139:2016	Stainless steel, 1.4401, 1.4404 or 1.4571, EN 10088:2014
6	Threaded cone	Steel EN 10083-2:2006	Stainless steel, 1.4401, 1.4404 or 1.4571, EN 10088:2014
7	Hexagon nut	Steel, Strength class 8, EN ISO 898-2:2012	Stainless steel, strength class 70, EN ISO 3506-2:2009
8	Hexagon head screw	Steel, Strength class 8.8, EN ISO 898-1:2013	Stainless steel, strength class 70, EN ISO 3506-1:2009
9	Countersunk screw	Steel, Strength class 8.8, EN ISO 898-1:2013	Stainless steel, strength class 70, EN ISO 3506-1:2009
10	Countersunk washer	Steel, EN 10083-2:2006	Stainless steel, 1.4401, 1.4404 or 1.4571, EN 10088:2014, zinc plated

**Highload Anchor SZ**

**Product description**  
Marking and materials

**Annex A2**



### Specification of intended use

Highload Anchor SZ, steel zinc plated	10/M6	12/M8	15/M10	18/M12	24/M16	24/ M16L	28/M20	32/M24
Static or quasi-static action	✓							
Seismic action (SZ-B and SZ-S)	-	C1 + C2						
Seismic action (SZ-SK)	-	C1 + C2				-		
Fire exposure	R 30 ... R 120							
Highload Anchor SZ, stainless steel A4	12/M8	15/M10	18/M12	24/M16				
Static or quasi-static action	✓							
Seismic action (SZ-B and SZ-S)	C1 + C2							
Seismic action (SZ-SK)	C1 + C2			-				
Fire exposure	R30 ... R120							

#### Base materials:

- Cracked and uncracked concrete
- Reinforced or unreinforced normal weight concrete according to EN 206-1:2000
- Strength classes C20/25 to C50/60 according to EN 206-1:2000

#### Use conditions (Environmental conditions):

- Structures subject to dry internal conditions (zinc plated steel or stainless steel).
- Structures subject to external atmospheric exposure (including industrial and marine environment) and to permanently damp internal conditions, if no particular aggressive conditions exist (stainless steel).

Note: Particular aggressive conditions are e.g. permanent, alternating immersion in seawater or the splash zone of seawater, chloride atmosphere of indoor pools or atmosphere with extreme chemical pollution (e.g. in desulphurization plants or road tunnels where de-icing materials are used.)

#### Design:

- Anchorages are designed under the responsibility of an engineer experienced in anchorages and concrete work.
- Verifiable calculation notes and drawings are prepared taking account of the loads to be anchored. The position of the anchor is indicated on the design drawings (e.g. position of the anchor relative to reinforcement or to supports, etc.).
- Anchorages under static or quasi-static actions, seismic actions and under fire exposure are designed in accordance with FprEN 1992-4:2016 and TR 055.

#### Installation:

- Anchor installation carried out by appropriately qualified personnel and under the supervision of the person responsible for technical matters on site.
- In case of aborted hole: new drilling at a minimum distance away of twice the depth of the aborted hole or smaller distance if the aborted drill hole is filled with high strength mortar and if under shear or oblique tension load it is not in the direction of load application.
- Anchor installation such that the effective anchorage depth is complied with. This compliance is ensured when the embedment mark of the anchor does no more exceed the concrete surface.
- Use as supplied by the manufacturer without replacing individual parts.
- Drilling of hole only by hammer drilling (use of vacuum drill bits is admissible)

### Highload Anchor SZ

Intended use  
Specification of intended use

Annex B1

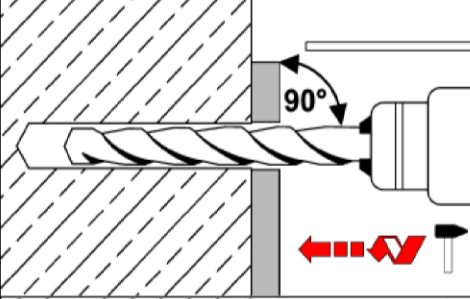
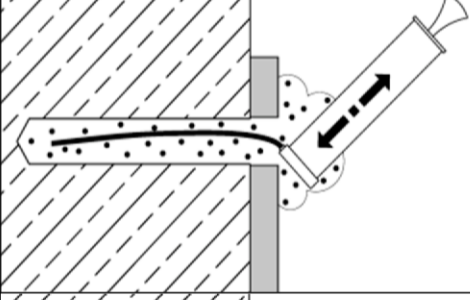
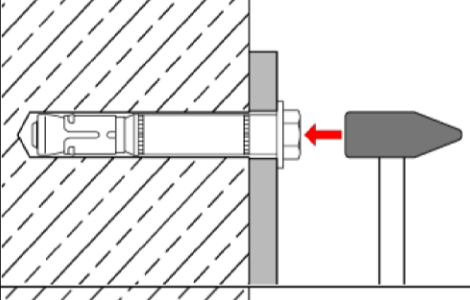
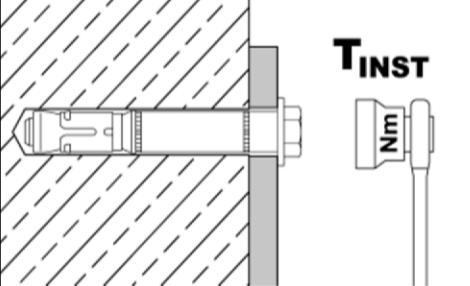

### Installation instructions

1		<p>Drill hole perpendicular to concrete surface. If using a vacuum drill bit, proceed with step 3.</p>
2		<p>Blow out dust. Alternatively vacuum clean down to the bottom of the hole.</p>
3		<p>Drive in anchor.</p>
4		<p>Apply installation torque <math>T_{inst}</math> by using calibrated torque wrench.</p>

### Highload Anchor SZ

Intended use  
Installation instructions

Annex B2

**Table B1: Installation parameters, steel zinc plated**

Anchor size		10/M6	12/M8	15/M10	18/M12	24/M16	24/M16L	28/M20	32/M24
Size of thread	[-]	M6	M8	M10	M12	M16	M16	M20	M24
Effective anchorage depth	$h_{ef}$ [mm]	50	60	71	80	100	115	125	150
Nominal diameter of drill bit	$d_0 =$ [mm]	10	12	15	18	24	24	28	32
Cutting diameter of drill bit	$d_{cut} \leq$ [mm]	10,45	12,5	15,5	18,5	24,55	24,55	28,55	32,7
Depth of drill hole	$h_1 \geq$ [mm]	65	80	95	105	130	145	160	180
Diameter of clearance hole in the fixture	$d_f \leq$ [mm]	12	14	17	20	26	26	31	35
Thickness of countersunk washer SZ-SK	$t_{sk}$ [mm]	4	5	6	7	-	-	-	-
Minimum thickness of fixture SZ-SK	$t_{fix \min}^{2)}$ [mm]	8	10	14	18	-	-	-	-
Installation torque	$T_{inst}$ (SZ-B, SZ-S) [Nm]	15	30	50	80	160	160	280	280
	$T_{inst}$ (SZ-SK) [Nm]	10	25	55	70	-	-	-	-
Minimum thickness of member	$h_{min}$ [mm]	100	120	140	160	200	230	250	300
Minimum spacing <sup>1) 3)</sup> cracked concrete	$s_{min}$ [mm]	50	50	60	70	100	100	125	150
	for $c \geq$ [mm]	50	80	120	140	180	180	300	300
Minimum edge distance <sup>1) 3)</sup> cracked concrete	$c_{min}$ [mm]	50	55	60	70	100	100	180	150
	for $s \geq$ [mm]	50	100	120	160	220	220	540	300
Minimum spacing <sup>1) 3)</sup> uncracked concrete	$s_{min}$ [mm]	50	60	60	70	100	100	125	150
	for $c \geq$ [mm]	80	100	120	140	180	180	300	300
Minimum edge distance <sup>1) 3)</sup> uncracked concrete	$c_{min}$ [mm]	50	60	60	70	100	100	180	150
	for $s \geq$ [mm]	100	120	120	160	220	220	540	300

<sup>1)</sup> Intermediate values by linear interpolation

<sup>2)</sup> Depending on the existing shear load, the thickness of the fixture may be reduced to the thickness of the countersunk washer  $t_{sk}$  (see Annex A2). It must be verified that the present shear load can be transferred completely into the distance sleeve (bearing of hole).

<sup>3)</sup> For fire exposure from more than one side  $c \geq 300$  mm or  $c_{min} \geq 300$  mm applies.

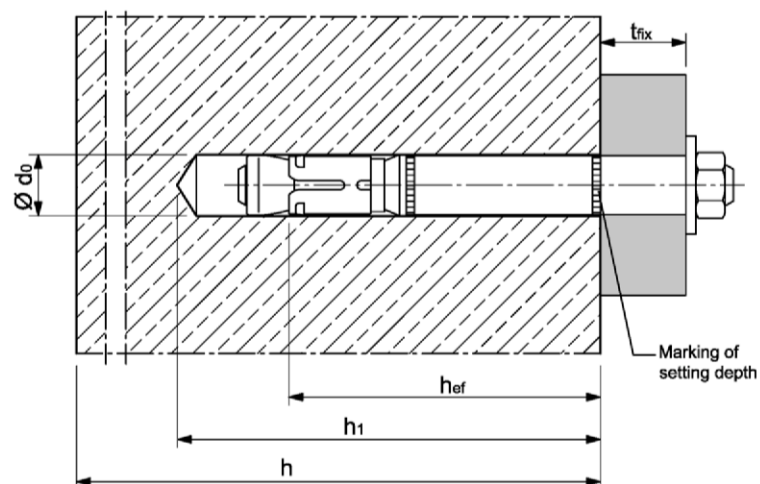

**Highload Anchor SZ**

**Intended use**  
Installation parameters, steel zinc plated

**Annex B3**

**Table B2: Installation parameters, stainless steel A4**

Anchor size			12/M8	15/M10	18/M12	24/M16
Size of thread		[-]	M8	M10	M12	M16
Effective anchorage depth	$h_{ef}$	[mm]	60	71	80	100
Nominal diameter of drill bit	$d_0 =$	[mm]	12	15	18	24
Cutting diameter of drill bit	$d_{cut} \leq$	[mm]	12,5	15,5	18,5	24,55
Depth of drill hole	$h_1 \geq$	[mm]	80	95	105	130
Diameter of clearance hole in the fixture	$d_f \leq$	[mm]	14	17	20	26
Thickness of countersunk washer SZ-SK	$t_{sk}$	[mm]	5	6	7	-
Minimum thickness of fixture SZ-SK	$t_{fix \min}^{2)}$	[mm]	10	14	18	-
Installation torque	$T_{inst}$ (SZ-B)	[Nm]	35	55	90	170
	$T_{inst}$ (SZ-S)	[Nm]	30	50	80	170
	$T_{inst}$ (SZ-SK)	[Nm]	17,5	42,5	50	-
Minimum thickness of member	$h_{min}$	[mm]	120	140	160	200
Minimum spacing <sup>1) 3)</sup> cracked concrete	$s_{min}$	[mm]	50	60	70	80
	for $c \geq$	[mm]	80	120	140	180
Minimum edge distance <sup>1) 3)</sup> cracked concrete	$c_{min}$	[mm]	50	60	70	80
	for $s \geq$	[mm]	80	120	160	200
Minimum spacing <sup>1) 3)</sup> uncracked concrete	$s_{min}$	[mm]	50	60	70	80
	for $c \geq$	[mm]	80	120	140	180
Minimum edge distance <sup>1) 3)</sup> uncracked concrete	$c_{min}$	[mm]	50	85	70	180
	for $s \geq$	[mm]	80	185	160	80

<sup>1)</sup> Intermediate values by linear interpolation

<sup>2)</sup> Depending on the existing shear load, the thickness of the fixture may be reduced to the thickness of the countersunk washer  $t_{sk}$  (see Annex A2). It must be verified that the present shear load can be transferred completely into the distance sleeve (bearing of hole).

<sup>3)</sup> For fire exposure from more than one side  $c \geq 300$  mm or  $c_{min} \geq 300$  mm applies.

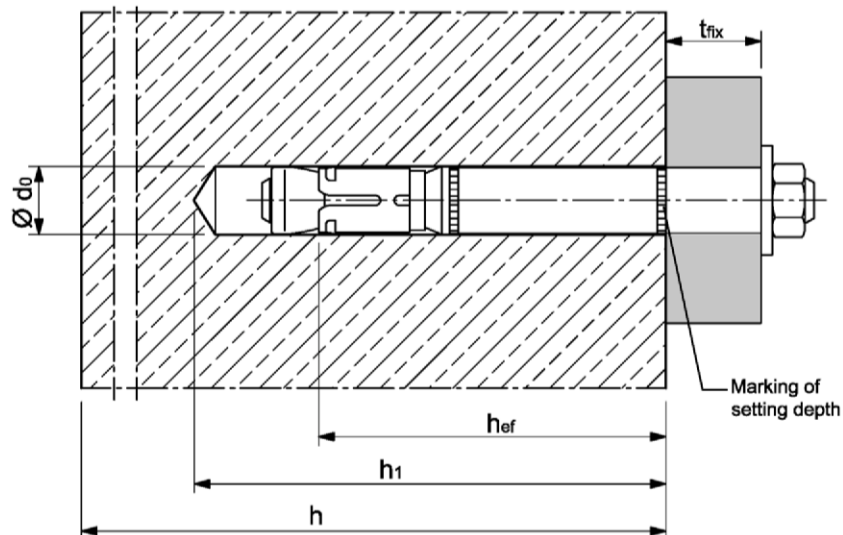

**Highload Anchor SZ**

**Intended use**  
Installation parameters, stainless steel A4

**Annex B4**

**Table C1:** Characteristic values for **tension load, cracked concrete,** static or quasi-static action, **steel zinc plated**

Anchor size			10/M6	12/M8	15/M10	18/M12	24/M16	24/ M16L	28/M20	32/M24
Installation safety factor	$\gamma_{inst}$	[-]	1,0							
<b>Steel failure</b>										
Characteristic resistance	$N_{Rk,s}$	[kN]	16	29	46	67	126	126	196	282
Partial safety factor	$\gamma_{Ms}$	[-]	1,5							
<b>Pull-out failure</b>										
Characteristic resistance in cracked concrete C20/25	$N_{Rk,p}$	[kN]	5	12	16	1)	1)	1)	1)	1)
Increasing factor for $N_{Rk,p}$	$\psi_C$	[-]	$\left(\frac{f_{ck}}{20}\right)^{0,5}$							
<b>Concrete cone failure</b>										
Effective anchorage depth	$h_{ef}$	[mm]	50	60	71	80	100	115	125	150
Factor $k_1 =$	$k_{cr,N}$	[-]	7,7							

1) Pull-out is not decisive

**Table C2:** Characteristic values for **tension load, cracked concrete,** static or quasi-static action, **stainless steel A4**

Anchor size			12/M8	15/M10	18/M12	24/M16
Installation safety factor	$\gamma_{inst}$	[-]	1,0			
<b>Steel failure</b>						
<b>SZ-B</b>						
Characteristic resistance	$N_{Rk,s}$	[kN]	26	41	60	110
Partial safety factor	$\gamma_{Ms}$	[-]	1,5			
<b>SZ-S and SZ-SK</b>						
Characteristic resistance	$N_{Rk,s}$	[kN]	26	41	60	110
Partial safety factor	$\gamma_{Ms}$	[-]	1,87			
<b>Pull-out failure</b>						
Characteristic resistance in cracked concrete C20/25	$N_{Rk,p}$	[kN]	9	16	1)	1)
Increasing factor for $N_{Rk,p}$	$\psi_C$	[-]	$\left(\frac{f_{ck}}{20}\right)^{0,5}$			
<b>Concrete cone failure</b>						
Effective anchorage depth	$h_{ef}$	[mm]	60	71	80	100
Factor $k_1 =$	$k_{cr,N}$	[-]	7,7			

1) Pull-out is not decisive

**Highload Anchor SZ**

**Performance**

Characteristic values for **tension load, cracked concrete,** static or quasi-static action

**Annex C1**

**Table C3:** Characteristic values for **tension load, uncracked concrete,** static or quasi-static action, **steel zinc plated**

Anchor size			10/M6	12/M8	15/M10	18/M12	24/M16	24/ M16L	28/M20	32/M24
Installation safety factor	$\gamma_{inst}$	[-]	1,0							
<b>Steel failure</b>										
Characteristic resistance	$N_{RK,s}$	[kN]	16	29	46	67	126	126	196	282
Partial safety factor	$\gamma_{Ms}$	[-]	1,5							
<b>Pull-out failure</b>										
Characteristic resistance in uncracked concrete C20/25	$N_{RK,p}$	[kN]	1)	20	1)	1)	1)	1)	1)	1)
Increasing factor for $N_{RK,p}$	$\psi_C$	[-]	$\left(\frac{f_{ck}}{20}\right)^{0,5}$							
<b>Splitting failure</b> (The higher resistance of case 1 and case 2 may be applied)										
Case 1										
Characteristic resistance in uncracked concrete C20/25	$N^0_{RK,sp}$	[kN]	12	16	25	30	40	70	50	70
Edge distance	$c_{cr,sp}$	[mm]	1,5 $h_{ef}$							
Increasing factor for $N^0_{RK,sp}$	$\psi_C$	[-]	$\left(\frac{f_{ck}}{20}\right)^{0,5}$							
Case 2										
Characteristic resistance in uncracked concrete	$N^0_{RK,sp}$	[kN]	$\min(N_{RK,p}; N^0_{RK,c})$							
Edge distance	$c_{cr,sp}$	[mm]	2,5 $h_{ef}$					1,5 $h_{ef}$	2,5 $h_{ef}$	2 $h_{ef}$
<b>Concrete cone failure</b>										
Effective Anchorage depth	$h_{ef}$	[mm]	50	60	71	80	100	115	125	150
Edge distance	$c_{cr,N}$	[mm]	1,5 $h_{ef}$							
Factor $k_1 =$	$k_{Ucr,N}$	[-]	11,0							

1) Pull-out is not decisive

**Highload Anchor SZ**

**Performance**

Characteristic values for **tension load, uncracked concrete,** static or quasi-static action, **steel zinc plated**

**Annex C2**

**Table C4:** Characteristic values for **tension load, uncracked concrete**, static or quasi-static action, **stainless steel A4**

Anchor size			12/M8	15/M10	18/M12	24/M16
Installation safety factor	$\gamma_{inst}$	[-]	1,0			
<b>Steel failure</b>						
<b>SZ-B</b>						
Characteristic resistance	$N_{Rk,s}$	[kN]	26	41	60	110
Partial safety factor	$\gamma_{Ms}$	[-]	1,5			
<b>SZ-S and SZ-SK</b>						
Characteristic resistance	$N_{Rk,s}$	[kN]	26	41	60	110
Partial safety factor	$\gamma_{Ms}$	[-]	1,87			
<b>Pull-out failure</b>						
Characteristic resistance in uncracked concrete C20/25	$N_{Rk,p}$	[kN]	16	25	35	1)
Increasing factor for $N_{Rk,p}$	$\psi_C$	[-]	$\left(\frac{f_{ck}}{20}\right)^{0,5}$			
<b>Splitting failure</b>						
Edge distance	$c_{cr,sp}$	[mm]	180	235	265	300
<b>Concrete cone failure</b>						
Effective anchorage depth	$h_{ef}$	[mm]	60	71	80	100
Edge distance	$c_{cr,N}$	[mm]	1,5 $h_{ef}$			
Factor $k_1 =$	$k_{Ucr,N}$	[-]	11,0			

1) Pull-out is not decisive.

**Highload Anchor SZ**

**Performance**

Characteristic values for **tension loads, uncracked concrete**, static or quasi-static action, **stainless steel A4**

**Annex C3**

**Table C5:** Characteristic values of **shear load**, static or quasi-static action, **steel zinc plated**

Anchor size			10/M6	12/M8	15/M10	18/M12	24/M16	24/ M16L	28/M20	32/M24
<b>Steel failure without lever arm</b>										
<b>SZ-B</b>										
Characteristic resistance	$V_{Rk,s}^0$	[kN]	16	25	36	63	91	91	122	200
Factor	$k_7$	[-]	1,0							
<b>SZ-S and SZ-SK</b>										
Characteristic resistance	$V_{Rk,s}^0$	[kN]	18	30	48	73	126	126	150	200
Factor	$k_7$	[-]	1,0							
Partial safety factor	$\gamma_{Ms}$	[-]	1,25							
<b>Steel failure with lever arm</b>										
Characteristic resistance	$M_{Rk,s}^0$	[Nm]	12	30	60	105	266	266	519	898
Partial safety factor	$\gamma_{Ms}$	[-]	1,25							
<b>Concrete pry-out failure</b>										
Factor	$k_8$	[-]	1,8	2,0						
<b>Concrete edge failure</b>										
Effective length of anchor in shear loading	$l_f$	[mm]	50	60	71	80	100	115	125	150
Outside diameter of anchor	$d_{nom}$	[mm]	10	12	15	18	24	24	28	32

**Highload Anchor SZ**

**Performance**  
Characteristic values for **shear load**, static or quasi-static action, **steel zinc plated**

**Annex C4**



**Table C6:** Characteristic values for **shear load**, static or quasi-static action, **stainless steel A4**

Anchor size			12/M8	15/M10	18/M12	24/M16
<b>Steel failure without lever arm</b>						
Characteristic resistance	$V^{0}_{Rk,s}$	[kN]	24	37	62	92
<b>SZ-B</b>						
Factor	$k_7$	[-]	1,0			
Partial safety factor	$\gamma_{Ms}$	[-]	1,25			
<b>SZ-S</b>						
Factor	$k_7$	[-]	1,0			
Partial safety factor	$\gamma_{Ms}$	[-]	1,36			
<b>SZ-SK</b>						
Factor	$k_7$	[-]	0,8			-
Partial safety factor	$\gamma_{Ms}$	[-]	1,36			-
<b>Steel failure with lever arm</b>						
Characteristic resistance	$M^0_{Rk,s}$	[Nm]	26	52	92	232
<b>SZ-B</b>						
Partial safety factor	$\gamma_{Ms}$	[-]	1,25			
<b>SZ-S and SZ-SK</b>						
Partial safety factor	$\gamma_{Ms}$	[-]	1,56			
<b>Concrete pry-out failure</b>						
Factor	$k_8$	[-]	2,0			
<b>Concrete edge failure</b>						
Effective length of anchor in shear loading	$l_f$	[mm]	60	71	80	100
Outside diameter of anchor	$d_{nom}$	[mm]	12	15	18	24

**Highload Anchor SZ**

**Performance**  
Characteristic values for **shear load**, static or quasi-static action,  
**stainless steel A4**

**Annex C5**

**Table C7:** Characteristic values for **seismic action, Category C1 and C2, steel zinc plated**

Anchor size			12/M8	15/M10	18/M12	24/M16	24/M16L	28/M20	32/M24
Tension load									
Installation safety factor	$\gamma_{inst}$	[-]	1,0						
<b>Steel failure</b>									
Characteristic tension resistance category <b>C1</b>	$N_{Rk,s,eq,C1}$	[kN]	29	46	67	126	126	196	280
Characteristic tension resistance category <b>C2</b>	$N_{Rk,s,eq,C2}$	[kN]	29	46	67	126	126	196	280
Partial safety factor	$\gamma_{Ms}$	[-]	1,5						
<b>Pull-out failure</b>									
Characteristic tension resistance category <b>C1</b>	$N_{Rk,p,eq,C1}$	[kN]	12	16	25	36	44,4	50,3	63,3
Characteristic tension resistance category <b>C2</b>	$N_{Rk,p,eq,C2}$	[kN]	5,4	16,4	22,6	29,0	41,2	43,6	63,3
<b>Shear load</b>									
<b>Steel failure without lever arm</b>									
<b>SZ-B</b>									
Characteristic shear resistance category <b>C1</b>	$V_{Rk,s,eq,C1}$	[kN]	18,0	27,1	43,4	51,9	51,9	96,4	160,1
Characteristic shear resistance category <b>C2</b>	$V_{Rk,s,eq,C2}$	[kN]	12,7	20,5	31,5	50,1	50,1	67,1	108,1
<b>SZ-S</b>									
Characteristic shear resistance category <b>C1</b>	$V_{Rk,s,eq,C1}$	[kN]	18,0	27,1	43,4	51,9	51,9	96,4	160,1
Characteristic shear resistance category <b>C2</b>	$V_{Rk,s,eq,C2}$	[kN]	12,7	20,5	31,5	69,3	69,3	67,1	108,1
<b>SZ-SK</b>									
Characteristic shear resistance category <b>C1</b>	$V_{Rk,s,eq,C1}$	[kN]	25,2	36,5	50,4	-	-	-	-
Characteristic shear resistance category <b>C2</b>	$V_{Rk,s,eq,C2}$	[kN]	19,2	29,3	39,4	-	-	-	-
Partial safety factor	$\gamma_{Ms}$	[-]	1,25						

**Highload Anchor SZ**

**Performance**  
Characteristic values for **seismic action, steel zinc plated**

**Annex C6**

**Table C8:** Characteristic values for **seismic action, Category C1 and C2, stainless steel A4**

Anchor size			12/M8	15/M10	18/M12	24/M16
<b>Tension load</b>						
Installation safety factor	$\gamma_{inst}$	[-]	1,0			
<b>Steel failure</b>						
Characteristic tension resistance, category <b>C1</b>	$N_{Rk,s,eq,C1}$	[kN]	26	41	60	110
Characteristic tension resistance, category <b>C2</b>	$N_{Rk,s,eq,C2}$	[kN]	26	41	60	110
Partial safety factor <b>SZ-B</b>	$\gamma_{Ms}$	[-]	1,5			
Partial safety factor <b>SZ-S and SZ-SK</b>	$\gamma_{Ms}$	[-]	1,87			
<b>Pull-out failure</b>						
Characteristic tension resistance, category <b>C1</b>	$N_{Rk,p,eq,C1}$	[kN]	9	16	26	36
Characteristic tension resistance, category <b>C2</b>	$N_{Rk,p,eq,C2}$	[kN]	4,8	16,5	24,8	44,5
<b>Shear load</b>						
<b>Steel failure without lever arm</b>						
<b>SZ-B</b>						
Characteristic shear resistance, category <b>C1</b>	$V_{Rk,s,eq,C1}$	[kN]	9,6	13,3	25,4	75,4
Characteristic shear resistance, category <b>C2</b>	$V_{Rk,s,eq,C2}$	[kN]	9,7	14,0	18,0	32,2
Partial safety factor	$\gamma_{Ms}$	[-]	1,25			
<b>SZ-S</b>						
Characteristic shear resistance, category <b>C1</b>	$V_{Rk,s,eq,C1}$	[kN]	9,6	13,3	25,4	75,4
Characteristic shear resistance, category <b>C2</b>	$V_{Rk,s,eq,C2}$	[kN]	9,7	14,0	18,0	32,2
Partial safety factor	$\gamma_{Ms}$	[-]	1,36			
<b>SZ-SK</b>						
Characteristic shear resistance, category <b>C1</b>	$V_{Rk,s,eq,C1}$	[kN]	11,5	23,3	31,6	-
Characteristic shear resistance, category <b>C2</b>	$V_{Rk,s,eq,C2}$	[kN]	10,8	17,4	15,4	-
Partial safety factor	$\gamma_{Ms}$	[-]	1,36			

**Highload Anchor SZ**

**Performance**  
Characteristic values for **seismic action, stainless steel A4**

**Annex C7**

**Table C9:** Characteristic values under **fire exposure** in cracked and uncracked concrete C20/25 to C50/60

Anchor size		10/M6	12/M8	15/M10	18/M12	24/M16	24/ M16L	28/M20	32/M24	
<b>Tension load</b>										
<b>Steel failure</b>										
<b>Steel zinc plated</b>										
Characteristic resistance	R30	$N_{Rk,s,fi}$ [kN]	1,0	1,9	4,3	6,3	11,6	18,3	26,3	
	R60		0,8	1,5	3,2	4,6	8,6	13,5	19,5	
	R90		0,6	1,0	2,1	3,0	5,0	7,7	12,6	
	R120		0,4	0,8	1,5	2,0	3,1	4,9	9,2	
<b>Stainless steel A4</b>										
Characteristic resistance	R30	$N_{Rk,s,fi}$ [kN]	-	6,1	10,2	15,7	29,2	-	-	-
	R60		-	4,4	7,3	11,1	20,6	-	-	-
	R90		-	2,6	4,3	6,4	12,0	-	-	-
	R120		-	1,8	2,8	4,1	7,7	-	-	-
<b>Shear load</b>										
<b>Steel failure without lever arm</b>										
<b>Steel zinc plated</b>										
Characteristic resistance	R30	$V_{Rk,s,fi}$ [kN]	1,0	1,9	4,3	6,3	11,6	18,3	26,3	
	R60		0,8	1,5	3,2	4,6	8,6	13,5	19,5	
	R90		0,6	1,0	2,1	3,0	5,0	7,7	12,6	
	R120		0,4	0,8	1,5	2,0	3,1	4,9	9,2	
<b>Stainless steel A4</b>										
Characteristic resistance	R30	$V_{Rk,s,fi}$ [kN]	-	14,3	22,7	32,8	61,0	-	-	-
	R60		-	11,1	17,6	25,5	47,5	-	-	-
	R90		-	7,9	12,6	18,3	34,0	-	-	-
	R120		-	6,3	10,0	14,6	27,2	-	-	-
<b>Steel failure with lever arm</b>										
<b>Steel zinc plated</b>										
Characteristic resistance	R30	$M^0_{Rk,s,fi}$ [Nm]	0,8	2,0	5,6	9,7	24,8	42,4	83,6	
	R60		0,6	1,5	4,1	7,2	18,3	29,8	61,9	
	R90		0,4	1,0	2,7	4,7	11,9	17,1	40,1	
	R120		0,3	0,8	1,9	3,1	6,6	10,7	29,2	
<b>Stainless steel A4</b>										
Characteristic resistance	R30	$M^0_{Rk,s,fi}$ [Nm]	-	6,2	13,2	24,4	61,8	-	-	-
	R60		-	4,5	9,4	17,2	43,6	-	-	-
	R90		-	2,7	5,6	10,0	25,3	-	-	-
	R120		-	1,8	3,6	6,4	16,2	-	-	-

If pull-out is not decisive in equation D.4 and D.5, FprEN 1992-4:2016  $N_{Rk,p}$  must be replaced by  $N^0_{Rk,c}$ .

**Highload Anchor SZ**

**Performance**  
Characteristic values under **fire exposure**

**Annex C8**

**Table C10: Displacements under tension and shear load, steel zinc plated**

Anchor size			10/ M6	12/ M8	15/ M10	18/ M12	24/ M16	24 /M16L	28/ M20	32/ M24
<b>Tension load</b>										
Tension load in cracked concrete	N	[kN]	2,4	5,7	7,6	12,3	17,1	21,1	24	26,2
Displacement	$\delta_{N0}$	[mm]	0,5	0,5	0,5	0,7	0,8	0,7	0,9	1,4
	$\delta_{N\infty}$	[mm]	2,0	2,0	1,3	1,3	1,3	1,3	1,4	1,9
Tension load in uncracked concrete	N	[kN]	8,5	9,5	14,3	17,2	24	29,6	34	43
Displacement	$\delta_{N0}$	[mm]	0,8	1,0	1,1		1,3		0,3	0,7
	$\delta_{N\infty}$	[mm]	3,4		1,7		2,3		1,4	0,7
<b>Seismic action C2</b>										
Displacement for DLS	$\delta_{N,eq (DLS)}$	[mm]	-	3,3	3,0	5,0	3,0	3,0	4,0	5,3
Displacement for ULS	$\delta_{N,eq (ULS)}$	[mm]	-	12,2	11,3	16,0	9,2	9,2	13,8	12,4
<b>Shear load</b>										
<b>SZ-B</b>										
Shear load in cracked and uncracked concrete	V	[kN]	9,1	14	20,7	35,1	52,1	52,1	77	86,6
Displacement	$\delta_{V0}$	[mm]	2,5	2,1	2,7	3,0	5,1	5,1	4,3	10,5
	$\delta_{V\infty}$	[mm]	3,8	3,1	4,1	4,5	7,6	7,6	6,5	15,8
<b>Seismic action C2</b>										
Displacement for DLS	$\delta_{V,eq (DLS)}$	[mm]	-	2,3	3,1	3,0	2,6	2,6	1,6	6,1
Displacement for ULS	$\delta_{V,eq (ULS)}$	[mm]	-	4,8	6,4	6,1	6,6	6,6	4,8	9,5
<b>SZ-S</b>										
Shear load in cracked and uncracked concrete	V	[kN]	10,1	17,1	27,5	41,5	72	72	77	86,6
Displacement	$\delta_{V0}$	[mm]	2,9	2,5	3,6	3,5	7,0	7,0	4,3	10,5
	$\delta_{V\infty}$	[mm]	4,4	3,8	5,4	5,3	10,5	10,5	6,5	15,8
<b>Seismic action C2</b>										
Displacement for DLS	$\delta_{V,eq (DLS)}$	[mm]	-	2,3	3,1	3,0	3,3	3,3	1,6	6,1
Displacement for ULS	$\delta_{V,eq (ULS)}$	[mm]	-	4,8	6,4	6,1	8,2	8,2	4,8	9,5
<b>SZ-SK</b>										
Shear load in cracked and uncracked concrete	V	[kN]	10,1	17,1	27,5	41,5	-	-	-	-
Displacement	$\delta_{V0}$	[mm]	2,9	2,5	3,6	3,5	-	-	-	-
	$\delta_{V\infty}$	[mm]	4,4	3,8	5,4	5,3	-	-	-	-
<b>Seismic action C2</b>										
Displacement for DLS	$\delta_{V,eq (DLS)}$	[mm]	-	3,1	3,9	3,9	-	-	-	-
Displacement for ULS	$\delta_{V,eq (ULS)}$	[mm]	-	10,2	11,8	13,0	-	-	-	-

**Highload Anchor SZ**

**Performance**  
Displacements under tension and shear load, steel zinc plated

**Annex C9**

**Table C11:** Displacements under tension and shear load, **stainless steel A4**

Anchor size			12/M8	15/M10	18/M12	24/M16
<b>Tension load</b>						
Tension load in cracked concrete	N	[kN]	4,3	7,6	12,1	17,0
Displacement	$\delta_{N0}$	[mm]	0,5	0,5	1,3	0,5
	$\delta_{N\infty}$	[mm]	1,2	1,6	1,8	1,6
Tension load in uncracked concrete	N	[kN]	7,6	11,9	16,7	24,1
Displacement	$\delta_{N0}$	[mm]	0,2	0,3	1,2	1,5
	$\delta_{N\infty}$	[mm]	1,1	1,1	1,1	1,1
<b>Seismic action C2</b>						
Displacement for DLS	$\delta_{N,eq}$ (DLS)	[mm]	4,7	4,5	4,3	4,9
Displacement for ULS	$\delta_{N,eq}$ (ULS)	[mm]	13,3	12,7	9,7	10,1
<b>Shear load</b>						
Shear load in cracked concrete	V	[kN]	13,9	21,1	34,7	50,8
Displacement	$\delta_{V0}$	[mm]	3,4	4,9	4,8	6,7
	$\delta_{V\infty}$	[mm]	5,1	7,4	7,1	10,1
<b>Seismic action C2</b>						
<b>SZ-B, SZ-S</b>						
Displacement for DLS	$\delta_{V,eq}$ (DLS)	[mm]	2,8	3,1	2,6	3,3
Displacement for ULS	$\delta_{V,eq}$ (ULS)	[mm]	5,6	5,8	5,0	6,9
<b>SZ-SK</b>						
Displacement for DLS	$\delta_{V,eq}$ (DLS)	[mm]	2,5	2,8	2,9	-
Displacement for ULS	$\delta_{V,eq}$ (ULS)	[mm]	5,8	5,9	6,9	-

**Highload Anchor SZ**

**Performance**  
Displacements under tension and shear load, **stainless steel A4**

**Annex C10**